

Fastening Sets

Zinc Die Casting, for Cabinet U-Handles

SPECIFICATION

Fastening plates

Zinc die casting ZD

Powder coated

- Black, RAL 9005, textured finish **SW**
- Silver, RAL 9006, textured finish **SR**

Countersunk screws DIN 7991

Steel

Zinc plated, blue passivated



INFORMATION

Fastening sets GN 181 make it possible to mount different cabinet U-handles and tubular handles with internal thread from the operator's side.

The mounting position of the fastening plates is freely customizable, allowing a sideways offset or mounting with different drillhole spacings.

A fastening set consists of two fastening plates and two countersunk screws.

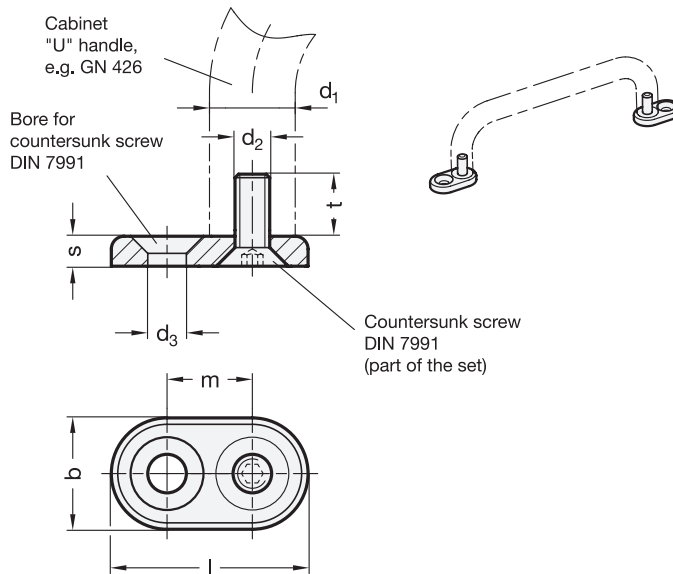

* Complete with

SW **SR**
RAL9005 RAL9006

GN 181

Description	d ₁	d ₂	b	d ₃ +0.2/+0.5	Length l	m	s	t	Countersunk screw DIN 7991	For Cabinet U-Handles	
GN 181-ZD-8-M4-*	8	M 4	10	4	20	10	3	7	M 4 x 10	GN 425-8-...	4
GN 181-ZD-10-M5-*	10	M 5	12	5	24	12	4	8	M 5 x 12	GN 425-10-... GN 425.1-10-...	8
GN 181-ZD-12-M6-*	12	M 6	15	6	30	15	4.5	9.5	M 6 x 14	GN 425-12-... GN 425.1-12-... GN 435-12-...	14
GN 181-ZD-16-M6-*	16	M 6	18	6	34	16	4.5	9.5	M 6 x 14	GN 425-16-... GN 435-16-...	22
GN 181-ZD-20-M6-*	20	M 6	22	6	40	18	4.5	9.5	M 6 x 14	GN 565-20-... GN 565.5-20-...	35
GN 181-ZD-20-M8-*	20	M 8	22	8	42	20	6	12	M 8 x 18	GN 426-20-... GN 426.1-20-...	55
GN 181-ZD-26-M8-*	26	M 8	28	8	52	24	6	12	M 8 x 18	GN 565-26-...	93
GN 181-ZD-28-M10-*	28	M 10	30	10	56	26	6.5	13.5	M 10 x 20	GN 426-28-... GN 426.1-28-...	89

Weight SW